

EHY-3000 series

Oncothermia systems for multi-local
cancer treatment



Oncotherm – About us

Oncotherm develops, manufactures and markets cancer treatment systems that utilize Oncothermia to treat tumors. Oncothermia is a further development of the classical method of Hyperthermia, one of the oldest cancer treatment methods, and it allows a personalized, non-toxic therapy using an electric field and promoting the body's natural regulatory processes. In accordance with its corporate philosophy, Oncotherm's mission is to heal cancer, to increase cancer patients' life expectancies and to improve patients' quality of life.

Oncothermia: how the method works and how it is used

A modulated electric field with a carrier frequency of 13.56 MHz is generated by two active electrodes. Since malignant tissue has higher conductivity than healthy human tissue, the electric field tends to flow predominantly through the malignant tumor tissue. The combination of deep-layer heating and the electric field leads to stimulation of malignant tumor cells. This, in turn, triggers increased apoptotic activity in the tumor region and as a result, promotes cell death.

Oncothermia: the method

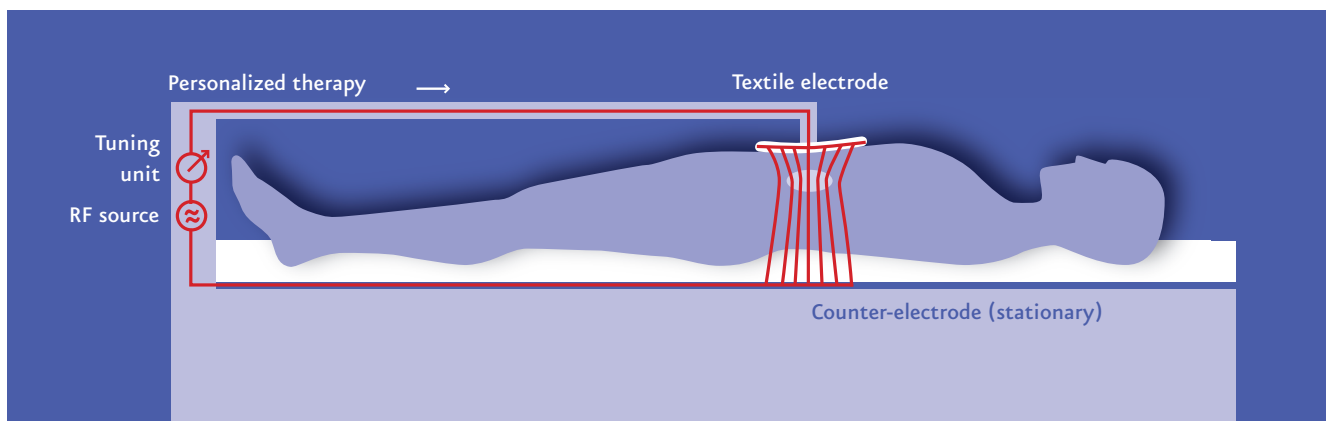

Schematic illustration of Oncothermia treatment. The illustration shows how the electric field, produced by the two active electrodes, passes through the patient's body. As shown schematically, the electric field tends to move through the pathways with the lowest impedance, i.e. through the malignant tissue (tumor).

Compared with classic Hyperthermia, which can result in burns, Oncothermia works at a significantly lower temperature. While classic Hyperthermia works at a temperature of 42°C, Oncothermia achieves a greater effect at just 38°C. Thanks to the selection at cellular level, the radiation only has an effect in the region of the tumor; the healthy regions remain as good as untouched. Of course, all electromagnetic radiation devices used for tumor treatment must fulfill stringent safety requirements. We meet such safety requirements via our own high standards and solid scientific findings, and via the low levels of radiation that our devices produce. Oncotherm systems are fitted with special 120 dB attenuation of the carrier frequency (i.e. the surrounding radiation is a million times lower than in the patient him/herself), so at an output of 150 W the radiation is less than 2 mW. All Oncotherm systems are classified according to the guidelines on electromagnetic compatibility.

Medical and therapeutic benefits

In general, Oncothermia can be used with all stages of cancer, although its current main use is with advanced solid tumors that are hardly operable or inoperable, as well as with recurrent tumors and metastases.

Where conventional therapy approaches (surgery, chemotherapy, radiation therapy) are not very likely to be successful, or have proven to be inadequate, Oncothermia may also be the choice for tumors not listed at the right, especially if the aim of therapy is palliation.

Oncothermia has already been successfully used with the following tumors, including their metastases in different organs:

- Astrocytomas and glioblastomas
- Bronchial carcinomas
- Cervix carcinomas
- Colorectal carcinomas
- Carcinomas of the urethra
- Hepatocellular carcinomas
- Stomach carcinomas
- Malignant melanomas
- Mamma carcinomas
- Renal cell carcinomas
- Esophagus carcinomas
- Ovarian carcinomas
- Pancreatic carcinomas
- Squamous epithelium carcinomas at head and throat

Additional average survival time after Oncothermia treatment, compared to SEER database

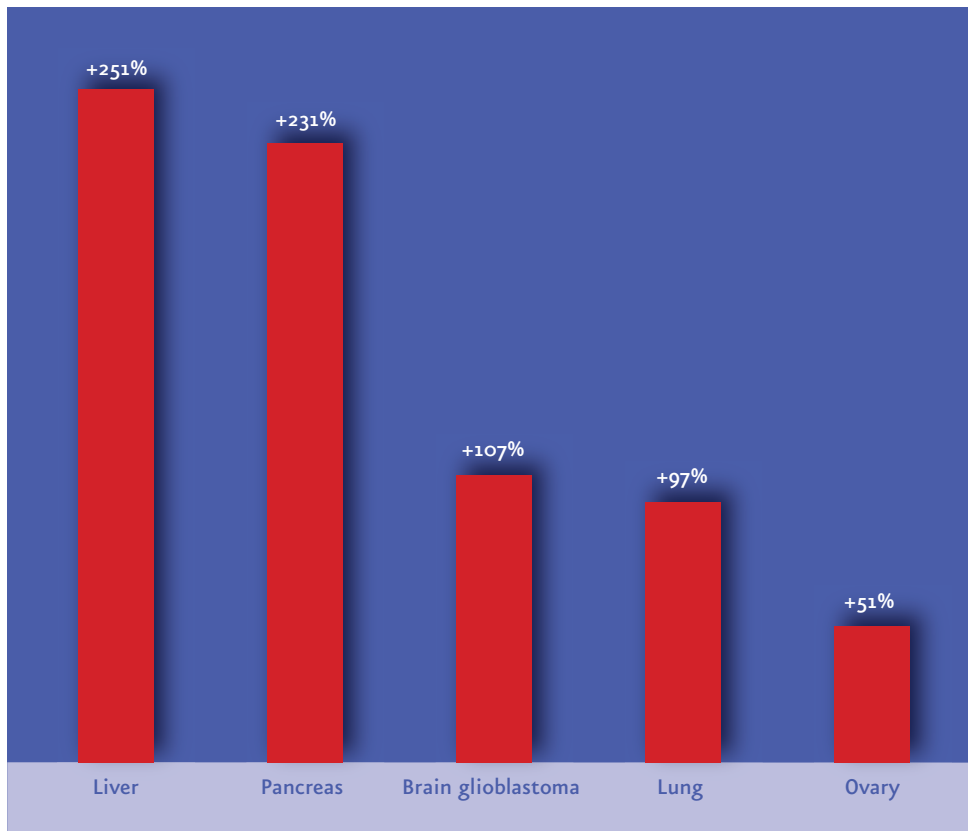

Results and numbers of cases from a large-scale retrospective study on the use of Oncothermia on different tumor entities. For all tumor entities studies, patients showed a higher survival rate in the first year after cancer diagnosis.

The EHY-3000 series

The EHY-3000 series with the EHY-3010 ML is a new development in the field of Oncothermia. Instead of a bolus electrode, this system uses textile electrodes, which are even more flexible to adjust to the treatment area. It is intended for use in the simultaneous multi-local treatment of advanced, metastasizing, malignant and solid tumors. Due to the highly flexible textile electrodes, almost all tumor locations can be treated.

The EHY-3000 series systems can also treat large body regions. The heating effect is however fundamentally different to whole-body heating: whole-body Hyperthermia heats the tumor through heated blood and the overall body temperature is increased in the process, while the EHY-3010 only heats the tumor.

The overall body temperature remains unchanged. The exclusive heating of the tumor without heating the whole body is highly significant for physiological reasons. This special feature of the EHY-3000 series means that, unlike with whole-body Hyperthermia, neither the patients' pulse nor their other vital signs deviate from the normal range. The treatment is straightforward both for the doctor and for the patient and the patient's body does not undergo additional stress. No preparatory procedures or follow-up treatments are required, which can be a major time factor in other treatments.

EHY-3000 series system
with monitor control panel
and textile electrode.



Main characteristics / differences

Compared with other therapy options, treatment with the EHY-3000 series offers many advantages without any major risks for the patient. The system is easy to use and control, so the treatment can also be carried out by nurses and doctors' assistants under the supervision of a doctor. Furthermore, the patient benefits enormously from the use of the latest technology: our systems meet the tough requirements of the EMC standard and the heat can be precisely targeted. Microwaves and radiation are not needed for this effect. The high degree of selectivity and multi-local focus are achieved through safe high-frequency resolution. Impedance is only very low.

The EHY-3000 series systems offer connectable modulation. The electrodes are noticeably light and can be easily adjusted to the patient's body shape. Unlike classic Hyperthermia treatments, the patient feels comfortable throughout the Oncothermia treatment and must not be afraid of an overheating of his/her skin's surface.

Multi-local Oncothermia treatment with the EHY-3010 ML system (with a large textile electrode) – Thermal image after 60 minutes of treatment

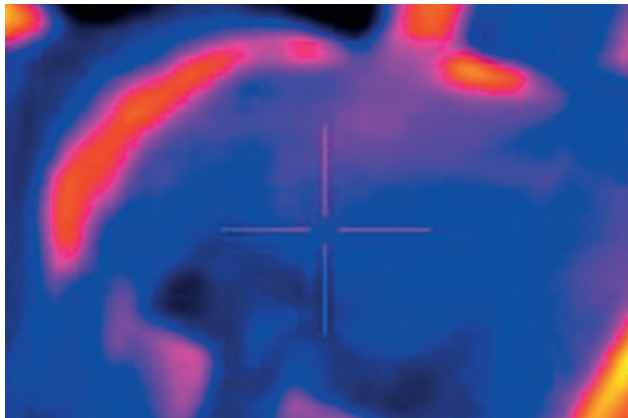

A heat camera clearly shows that the large electrode hardly heats up at all. The therapeutic effect, the heat, is produced deep within the body, not on its surface. The patient's safety is guaranteed.

Local Oncothermia treatment with the EHY-3010 ML system (with a small textile electrode) – Thermal image after 60 minutes of treatment

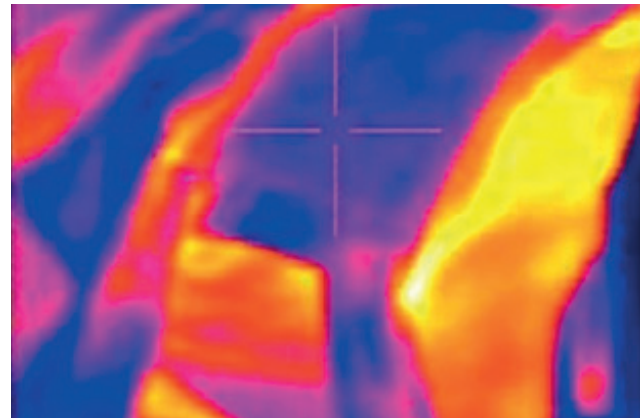

In local Oncothermia treatments with smaller electrodes as well, thermal images show that very little heat is generated in the vicinity of the electrode, but rather in the deeper regions of the body. In this case too, superficial skin burns are not a concern and the patient's safety is ensured.

Operation – Control - Safety

The EHY-3010 ML is the first Oncothermia system that enables multiple local treatments at the same time. This new and unique development allows you to provide better treatment to your patients, considering that patients' tumors have often already metastasized. Up until now, it was not possible to treat a number of metastases in a single procedure. In addition to the new treatment functions, the system's control options have also been improved. The system can now be controlled via a large LCD screen, as well as via your own computer and browser. This is another unique feature in the field of electro-Hyperthermia.

Thanks to the new EHY-3000 series, Hyperthermia treatment has made a breakthrough. It is not just the electrode system that has changed with the new system, the design has also been improved and the standard of operation, control and safety has increased. In addition to safety, increased effectiveness was also very important to us in the system's development. The EHY-3000 series incorporates more than 20 years of knowledge and experience, and takes into account all materials and components necessary for effective treatment and quality. The combination of all these elements makes the EHY-3010 ML an outstanding system that can achieve even better results with less energy.



The patient is positioned on the bed. The textile electrode is light and flexible and can be perfectly applied to the treatment area. Large tumors can also be optimally treated.



The monitor is used to control the system and displays the patient's treatment parameters.

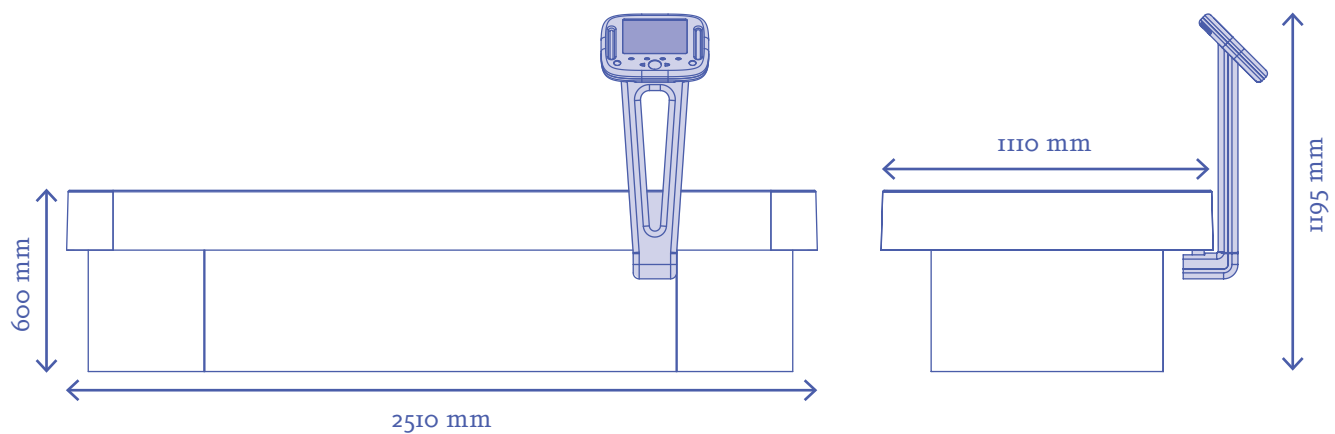

Technical data

Mains voltage	AC 230V/50Hz
Power input	1600 VA
Maximum power output	600 W
Nominal load	50 Ohm
Output carrier frequency	13.56 MHz
Output modulating frequency	Fractal noise
Weight	approx. 150 kg
Dimensions	600 x 2510 x 1110 mm (Height x Length x Width)
Height at the display	120 mm
Temperature	+10°C - +30°C
Relative humidity	20% - 60% (non-condensing)
Air pressure	700 hPa - 1060 hPa
Color	as per customer's request
Textile electrodes	
Standard electrodes	200 x 300 mm 300 x 400 mm
Personalized electrodes	Size, shape and personalized data as per customer's request

Product range

EHY-1020

The EHY-1020 is specifically designed to treat prostate diseases. Both malignant and benign tumors (BPH) can be treated using this system. It uses a catheter with built-in electronics and counter electrode. The EHY-1020 system is compact and easy to use. The method has been successfully used by our customers since 2010 with high success rates and minimal side effect.



EHY-2000plus

The EHY-2000plus is a widely accepted system for loco-regional deep mEHT applications. This model has been used for treatment worldwide for more than 20 years. Popular, versatile device, applicable for a range of solid tumors and improved over the years through feedback from our doctors, experts, the requirements of patients and the people treating them. The EHY-2000plus is an easy to use and highly reliable device.

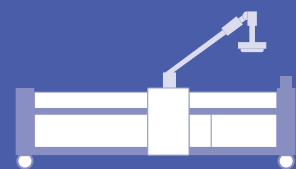

EHY-3010

The EHY-3010 is designed for the simultaneous multi-local treatment of advanced, metastatically disseminated, malignant and solid tumors. Within the range of Oncothermia systems, it is the pioneering breakthrough in the field of multi-local tumor therapy. Instead of a bolus electrode, this system uses textile electrodes, which are even more flexible to better adjust to the treatment area.



EHY-2030

The EHY-2030 is our latest development in the treatment of loco-regional (including deep seated and surface) tumors. The newly designed device includes the Smart Electrode System (SES), the plug-in Patient Management System (PMS-100) and a user-friendly touch screen display with full system control. The new RF generator with increased power has been developed with a new intelligently controlled step motor tuning system for rapid impedance matching to achieve faster tuning times.



www.Drei-K.de

Germany

Oncotherm GmbH
Belgische Allee 9
53842 Troisdorf
Germany
Phone +49 (0) 2241 31992-0
Fax +49 (0) 2241 31992-11
info@oncotherm.de
www.oncotherm.de

Hungary

Oncotherm Kft.
Gyár utca 2.
2040 Budaörs
Hungary
Phone +36 (06) 23 555-510
Fax +36 (06) 23 555-515
info@oncotherm.org
www.oncotherm.hu

USA

Oncotherm Ltd.
LLC, 1942
Broadway Street
Suite 314C
Boulder CO 80302
United States
Phone (406) 225-7009
www.oncotherm.com

